

# Overview and Operations of CubeSat FITSAT-1 (NIWAKA)

Takushi Tanaka\*, Yoshiyuki Kawamura\*\*,

\*Department of Computer Science and Engineering

\*\*Department of Intelligent Mechanical Engineering,  
Fukuoka Inst. Tech. Fukuoka, Japan  
tanaka@fit.ac.jp, kawamura@fit.ac.jp

Takakazu Tanaka

Logical Product Corporation  
Fukuoka, Japan  
tanaka@lp-d.co.jp

**Abstract**—FITSAT-1 (NIWAKA) is a 10 cm 1U CubeSat which was deployed from ISS/JEM on October 4, 2012. The main mission of NIWAKA is to demonstrate a high speed transmitter module developed by our group (115.2 kbps, 5.8 GHz, FSK, 2 W RF output). It can transmit VGA resolution jpeg images (640x480 pixels) in 2 to 6 seconds. The secondary mission is to make the satellite twinkle as an "artificial star" using high-output LEDs. This light was observed by binoculars, imaged by cameras, and detected by a photo-multiplier mounted on a telescope. We also discovered a phenomenon of increasing rotation of NIWAKA.

**Keywords**—cubesat; 5.8GHz; high speed transmission; 115.2 kbps; LED; optical communication; increasing rotation

## I. INTRODUCTION

FITSAT-1 (NIWAKA) is a 10 cm 1U Cube-Sat which was deployed from ISS/JEM on October 4, 2012. The main mission of NIWAKA is to demonstrate a high speed transmitter module developed by our group (115.2 kbps, 5.8 GHz, FSK, 2 W RF output). It can transmit a VGA resolution jpeg image (640x480 pixels) in 2 to 6 seconds. The secondary mission is to make the satellite twinkle as an "artificial star" using high-output LEDs. The light was observed by binoculars and pictured by camera. The optical signal was also detected by a photo-multiplier mounted on a telescope. These experiments were controlled by remote commands from the ground station using 437 MHz band and 1.26 GHz band Ham radio communication. We also discovered a phenomenon of increasing rotation of NIWAKA during its operation.

## II. STRUCTURE

### A. Body

The body of NIWAKA is made by cutting a section of 10cm square aluminum pipe. Both ends of the cut pipe are covered with aluminum panels as shown in Figure 1. The aluminum pipe is made of aluminum alloy A6063 and the panels are made of aluminum alloy A6061. The surface of the body is finished with black anodic coating (MIL-A-8625 Type 3 Class1). The CubeSat slide rails and side panels are not separate. They are made as a single unit. The thickness of the square pipe is 3mm. In order to make the 8.5 mm square CubeSat rails, 5.5mm square aluminum sticks (Figure 2) are attached to the four corners of the square pipe.

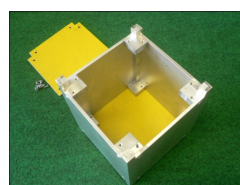

Fig. 1. Square Pipe



Fig. 2. Stick

### B. Surface

The top plane of NIWAKA has a 5.84 GHz patch antenna, fifty green LEDs, and a hole for front camera lens (Figure 3). The 5.84 GHz patch antenna is protected by a Teflon sheet and generates a right circularly polarized wave. The fifty green LEDs are driven by pulses of over 200 W. Each of four sides has two attached solar cells connected in series. The bottom plane has a 1.26 GHz patch antenna, thirty-two red LEDs, a hole for a rear camera lens, and a 437 MHz antenna which is extended 30 minutes after deployment (Figure 4).

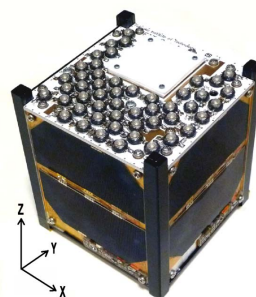

Fig. 3. NIWAKA (top)



Fig. 4. NIWAKA (bottom)

## III. ELECTRICAL POWER SYSTEM

The NIWAKA electrical power system consists of solar cells, a maximum power point tracker, DCDC-converters, a single lithium ion battery, three lithium ion batteries connected in series (Hitachi Maxell INR18650PB2, 1450 mAh), lithium ion battery controllers, two deployment switches, and a flight pin. All batteries have three independent switches connected in series on both the ground and source sides. Since these three switches are connected in series, none of the batteries supply powers until all of these three switches turn on. The single-cell battery supplies power for the 5 volt loads, which consist of

computers and low-speed communication system. The three-cell series-connected battery supplies power for the 5.84 GHz transmission and flashing LEDs experiments. Solar cells are attached to four sides of the satellite. Each side generates 2.3W (4.74V x 0.487A, maximum) of electric power. The generated power is withdrawn by a maximum power point tracker and fed to the 5 volt load and the lithium ion batteries.

#### IV. COMMUNICATION SYSTEM

The communication system consists of two uplinks and three downlinks as shown in Figure 5. The uplinks are used for remote commands. The 437 MHz band uses AX.25 packet radio at 1200 bps and the 1260 MHz band uses DTMF signals. The 1260 MHz uplink is designed as a backup system for the 437 MHz band.

On one of the downlinks, NIWAKA sends a CW beacon signal at 437.250 MHz at all times. This signal includes telemetry data such as voltages and currents of solar cells and batteries, temperatures, time-stamp, and other NIWAKA states. NIWAKA has another downlink, at 437.445 MHz, which transmits AX.25 packets at 1200bps. It is used to send stored telemetry data. NIWAKA has a third high speed downlink system for picture data. It uses 115.2 kbps FSK at 5.840 GHz. Table I summarizes the NIWAKA transmission frequencies and modulation types.

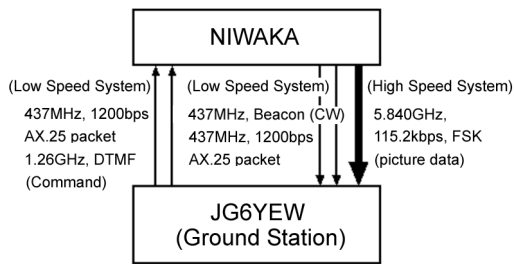

Fig. 5. Up-links and Down-links

TABLE I. TRANSMISSION FREQUENCY

Beacon	CW	437.250Mhz
Packet	1200bps, AX.25	437.445Mhz
Picture Data	115.2kbps FSK	5.840GHz

#### V. REMOTE COMMAND SYSTEM

Figure 6 shows the relationship between the remote command and communication systems. Remote commands are sent by AX.25 packets at 1200 bps using the 437 MHz band from the ground station. The packet signals are received by the 437 MHz band FM receiver and decoded by the TNC. The RX CPU executes the commands and outputs signals on the command bus line which connects between CPUs and peripherals. The results of the remote commands are monitored by the TX CPU. The TX CPU samples and stores the sensor data according to the received commands, and sends to the FM transmitter through the AX.25 TNC. The FM transmitter sends the AX.25 packet at 437.445 MHz with 800 mW output. The 1.26 GHz band RX also receives remote commands by DTMF

signal. These signals are decoded by a DTMF decoder and sent to the backup CPU. The backup CPU executes the command, and outputs signals on the command bus line.

The camera CPU receives the signal on the command bus line and executes the command. The shutter command takes 20 photographs and stores them in memory. The transmission command reads 20 photographs from memory and transmits the data over the 5.84 GHz transmitter.

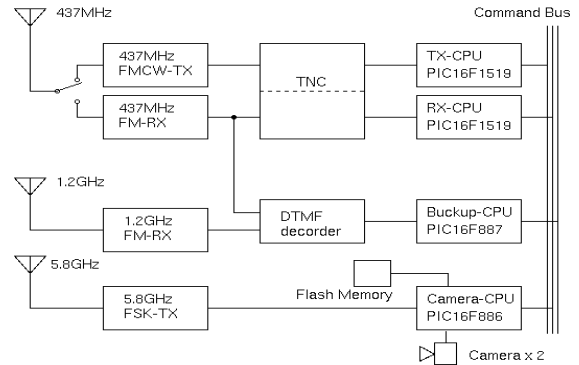

Fig. 6. Communication and Command System

#### VI. MISSION EQUIPMENT

##### A. High speed transmitter

The 5.84 GHz high-speed transmitter module was developed by our group (Figure 7). This module generates a 2 W RF output from a 15 W DC input. It can send digital signals at 115.2 kbps. A simple FSK modulation is used. Although its frequency deviation is  $\pm 50$  kHz, 99% of the energy is spread over 415 kHz. The 90% energy band may be less than 300 kHz.

The camera CPU not only controls two cameras (C1098 and Silent System) but also controls the PLL for the 5.84 GHz transmitter. These two cameras take photographs every 5 seconds alternatively by remote commands and 20 photographs are stored in flash memory as jpeg images. The camera CPU also reads the photographs from the memory in response to a transmission command, and sends the 20 photographs to the FSK modulator.

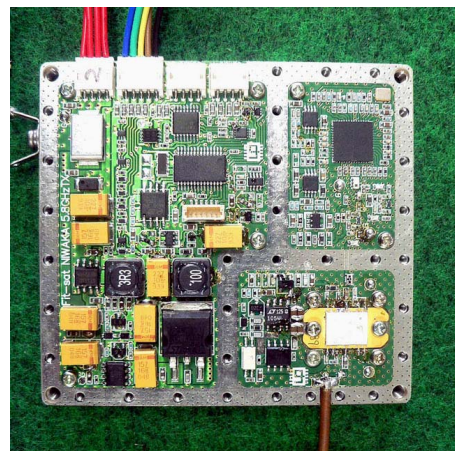

Fig.7 5.84 GHz High Speed Transmitter

## B. High Power LEDs

The top panel has fifty 3 W green LEDs (Figure 3). Two green LEDs are connected in series, and twenty five of these series LED pairs are connected in parallel (Figure 8). A current of almost 20A is applied and the LEDs are driven with more than 200 W pulse. The bottom panel (-Z plane) has thirty two 3 W red LEDs (Figure 4). Four red LEDs are connected in series, and eight of these sets of series LEDs are connected in parallel. A current of almost 10 A is applied and the LEDs are driven with more than 100 W pulse (Figure 9).

There are two LED drive modes. In Morse code mode, the signal is modulated with 1 kHz. If the light is observed on the ground and converted to an electrical signal, audio Morse code can be generated simply by connecting it to an audio amplifier and speaker. The duty of the 1 kHz pulse is 15%, so average power of green LEDs is  $220 \times 0.15 = 33$  W and that of the red LEDs is  $100 \times 0.15 = 15$  W.

The other mode is the faint light detection mode. In this mode, the LED drive current is modulated with both a 10 Hz signal and a 5 kHz signal. The light is received by a photomultiplier equipped telescope aligned with a 5.84 GHz parabolic antenna. Since both the 10 Hz and 5 kHz signal have duty ratio of 30 %, the average power of the green LEDs will be almost  $220 \times 0.3 \times 0.3 = 20$  W and that of the red LEDs will be around 10 W.

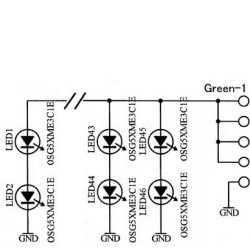

Fig. 8. Green LEDs

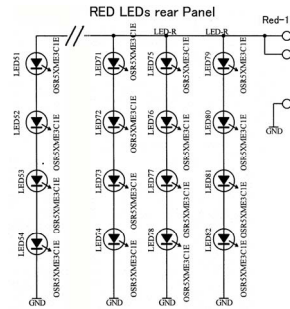

Fig. 9. Red LEDs

## VII. ORBIT AND POSTURE CONTROL

The orbit of the ISS is inclined 51.6 degrees from the equator. Since NIWAKA is deployed from ISS, its orbit will be almost the same as that of the ISS. Since a permanent magnet is mounted in NIWAKA, the top plane (+Z plane) of the body always faces magnetic north like a compass. The top plane has a 5.84 GHz patch antenna, LEDs, and a hole for the camera lens. When NIWAKA rises above the horizon, it will be to the south of the Fukuoka ground station, and both the 5.84 GHz antenna and the LEDs will be aimed accurately enough by the magnet aligning itself with the Earth's magnetic field. The 437 MHz antenna element is extended 17 cm by a small servomotor through the antenna hole in the bottom plane (-Z plane) like a tail. Since the element will be aligned with the Earth's magnetic field, we will observe the element from the axial direction in the south pass and thus the antenna gain will be the minimum. In the north pass, the antenna element will be rotated to a vertical orientation relative to our location, and the antenna gain will be the maximum.

## VIII. BEACON SIGNAL

### A. Signal Format

NIWAKA uses 437.250 MHz for beacon transmission. The beacon signal is a standard Morse code CW signal. The signal starts with "HI DE NIWAKA ..." and telemetry data follows as shown in Table III.

TABLE II. BEACON FORMAT

HI DE NIWAKA JAPAN				
S1	s11	s12	s13	s14
S2	s21	s22	s23	s24
S3	s31	s32	s33	s34
S4	s41	s42	s43	s44
S5	s51	s52	s53	s54

TABLE III. TELEMETRY DATA

s11: RSSI of 437MHz RX	s11x(5/256) [V]
s12: Total voltage of solar panel	s12x(5/256) [V]
s13: Total current of solar panel	s13x(5/256)x0.4 [A]
s14: V. of one cell lithium ion battery	s14x(5/256) [V]
s21: Current of one cell lithium ion battery	(s21x(5/256)-2.5)x0.4 [A]
	(>0: discharge)
	(<0: charge)
s22: V. of 3 cells lithium ion battery	s22x(5/256) [V]
s23: Current of 3 cells lithium ion battery	(s23x(5/256)-2.5)x10 [A]
	(s23x(5/256)-2.5)x0.1 [A]
	(>0: discharge)
	(<-0: charge)
s24: standard voltage of 2.5V	s24x(5/256) [V]
s31: V. of Solar panel (+X)	s3?x(4.5/256)*2 [V]
s32: V. of Solar panel (+Y)	
s33: V. of Solar panel (-X)	
s34: V. of Solar panel (-Y)	
s41: Temp. of 3 cell battery	(s4?x(4.5/256)-0.5)/0.01 [degC]
s42: Temp. of one cell battery	
s43: Temp. of +Z panel	
s44: Temp. of -Z panel	
s51: RSSI of 1.2GHz	s51x(4.5/256) [V]
s52-54: Time after last reset	s51x65536+s52x256+s53 [sec]

### B. Signal Reports

The beacon signal was received all over the world, and we already received more than one thousand signal and telemetry reports. An interesting one, from ham radio operator DF3GJ, showed a changing signal strength on 8th Nov. 2012 (Figure 10). From the graph, we inferred that NIWAKA is tumbling with a 28.5 second period.

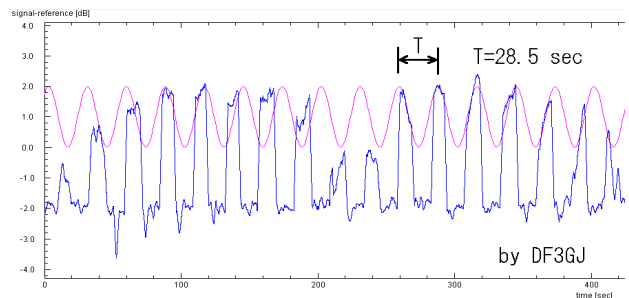

Fig. 10. Changing Signal Strength of Beacon

Everyday reports from ham radio operator VK5HI generated an interesting result. NIWAKA has four temperature sensors to measure batteries and LED-panels. Using his data, I have plotted the temperatures which were measured in morning (Figure 11). All of the temperatures have a peak around 4th Jan. 2013. On that day, the orbital plane of NIWAKA turned towards the sun. This implies that longer periods of sunshine increase the satellite's temperature.

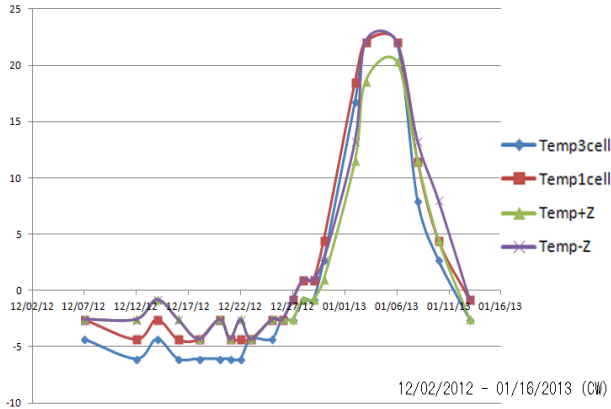

Fig. 11. Changing Temperatures around 4th Jan. 2013

### IX. STORED SENSOR DATA

#### A. Changing Temperature

TX CPU in Figure 6 stores 90 telemetry data items. Using the packet radio, we can download this stored data. Figure 12 shows temperature changes during 450 minutes from 23:30(JST) on 13th Oct. 2012 using a 5-minute sampling period. Thus there are almost 5 cycles of orbit. The blue line shows the temperature of the three-cell battery connected in series, which supplies power for 5.84 GHz high-speed transmission and the flashing LEDs. The red line shows the temperature of single-cell battery which supplies power for the UHF radio and CPUs. Since the single-cell battery is always either charging or discharging, its temperature is 2 degrees higher than that of the three-cell battery. The green line shows the temperature of +Z plane (top) while the purple line shows the temperature of -Z plane (bottom). Both planes change from -15 to +10 degree(C).

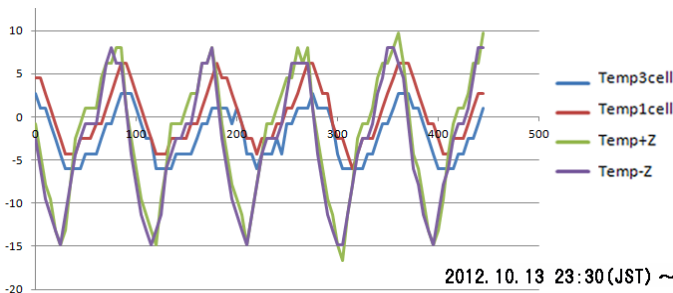

Fig. 12. Changing Temperatures

Figure 13 shows temperature changes during the 90 minutes from 22:53:30 (JST) on 1st Feb. 2013 using a 1-minute sampling period.

The flashing LED experiment starts 10 minutes after recording and continues for 2 minutes. The temperature of the green LED panel (+Z plane) increases 15 degrees and soon decreases. The three-cell battery temperature increases 10 degrees and then decreases slowly because of their thermal capacity. Since the single-cell battery is adjacent to the three-cell battery, its temperature also increases due to heat conduction. NIWAKA enters into a sunlit area after 35 minutes and all temperatures increase.

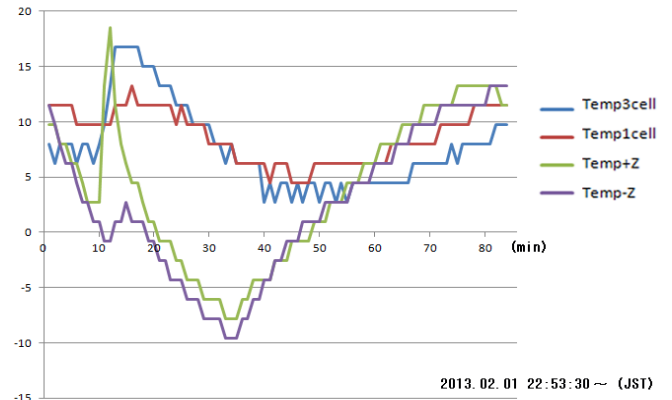

Fig. 13. Changing Temperature on Flashing LEDs

#### B. Changing Voltages and Currents of 3 cell Batteries

Figure 14 shows the current through the three-cell battery in the experiments of 1st Feb. The current increases from 3.3 to 4.4 amperes around 10 minutes after recording. The current continues for 2 minutes for the flashing LED experiment and then goes to zero. The negative current 35 minutes later indicates that solar charging has started.

Figure 15 shows the changing voltage of the three-cell battery. The voltage falls from 12.7 V to 11.6 V due to the flashing LED current. The voltage recovers to 12.3 V after flashing completes. At least two cycles are needed for the voltages to recover fully.

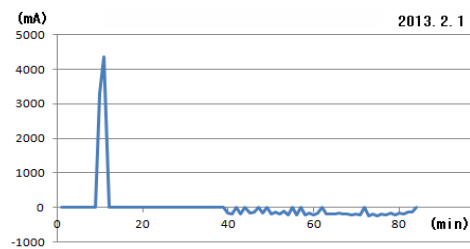

Fig. 14. Current of 3 cell Batteries

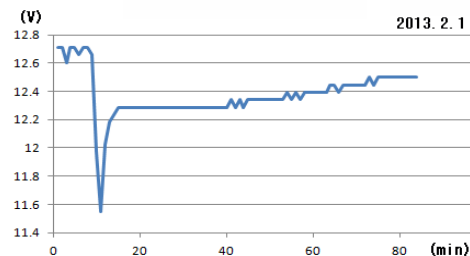

Fig. 15. Voltage of 3 cell Batteries

In order to see the detail of current and voltage change during flashing LED, the following 6 seconds of sampling is useful. Figure 16 shows the current of the three-cell battery around flashing and Figure 17 shows its voltage. As temperature of the LEDs increases, the characteristic curve moves to the left and then the current increases. The temperature of the batteries also increases and then its chemical reaction becomes active. Both reasons cause increases in the LED current.

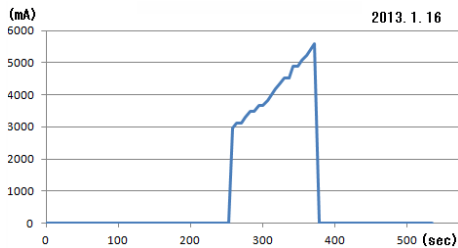

Fig. 16. Current of 3 cell batteries

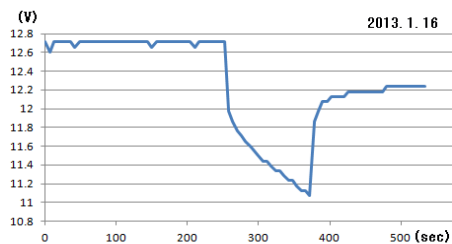

Fig. 17. Voltage of 3 cell Battery

### C. Changing Voltages of Solar Batteries

Figure 18 shows the changing voltage generated by solar panels using a 3-second sampling period from 11:24 on 6th Nov. 2012. The voltages change in the X, Y, -X, and -Y directions. This means NIWAKA is turning about the Z axis (Figure 3). The period of rotation is 33 seconds. These data were measured at a time when NIWAKA was passing over a dawn area. That is, NIWAKA is sunlit, but the ground is still dark. If we measure the same data around middle of a day, reflection from the ground generates voltages, and the graphs become flat.

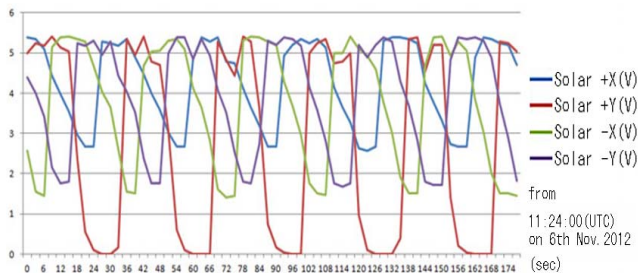

Fig. 18. Voltage Change of Solar Cells on 6th Nov.2012

Figure 19 shows the similar solar voltage data which was measured on 8th Feb. 2013 using 1 sec sampling. The period of rotation becomes 12.4 seconds. From these solar data, we have noticed that the rotation speed increases as shown in Figure 20.

The period from Figure 10 is also shown on this graph. We are now developing a model for this increasing rotation, which will be discussed in another paper.

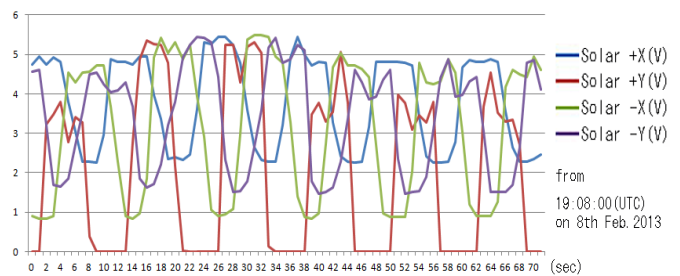

Fig. 19. Voltage Change of Solar Cells on 8th Feb.2013.

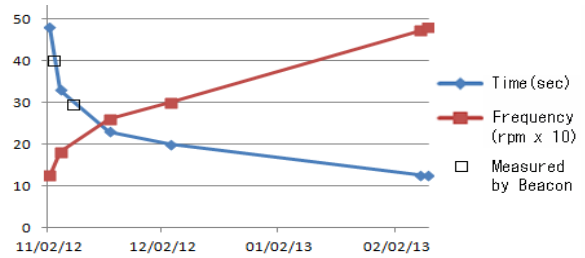

Fig. 20. Increasing Speed of Rotation

## X. 5.84 GHz EXPERIMENT

In order to receive 5.84 GHz signal, we have developed a LNB (low noise amplifier and frequency converter) which is attached to the focal point of a 1.2 m parabola dish. It converts 5.84 GHz to 440 MHz. Since the beam width of the 1.2 m dish is only 3 degree, we could not use a rotator for Yagi-antenna because of backlash. So we mounted the antenna on an equatorial telescope (Figure 22). It could point accurately, but it couldn't move fast enough. So we could receive only 4 or 5 pictures at a time. The 440 MHz signal is received by an AR8600 receiver and converted to 10.7 MHz to detect the FSK signal. The 10.7 MHz detector that we developed generates an RS232C serial signal that is input to a personal computer.

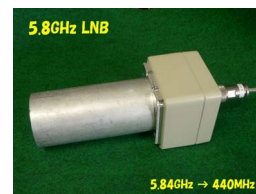

Fig. 21. 5.84 GHz LNB



Fig. 22. Dish on Equatorial Telescope

A single jpeg picture is sent with 128 bytes packets as shown in Table IV. Here, the first 4 bytes and the last 2 bytes do not consist of photographic data. The data size of all packets except the last is 122 (=7A hex) bytes. The jpeg photograph is reconstructed by connecting the data part of each packet by removing the first 4 byte and the last 2 byte. A total of 20 VGA photographs are sent at a time. Each picture is sent in around 2 to 6 seconds. There is an 8 ms interval between packets and a 5 second interval between photographs.

TABLE IV. PICTURE PACKET

Packet ID (2 byte)	Data Size (2 byte)	Photo Data (122 byte)	Verify (2 byte)

Figure 23 shows the first picture we received from NIWAKA. The 5.84 GHz signal from NIWAKA has been received not only by our ground station but also by JA0CAW Niigata, Japan, JA1OGZ Yokohama, Japan, N1JEZ Vermont, USA and Bochum Germany. AMSAT-DL team used 20m dish at Bochum and received 14 of 20 pictures at a time.



Fig. 23. First Picture Received (Rear Camera)



Fig. 24. Picture by Front Camera

## XI. FLASHING LEDS

The flashing LED experiment started 21st Nov. 2012. The first optical signal was photographed by Mr. K. Mishima at Kurashiki Science Center Japan and Prof. Jun-Ho Oh of KAIST Korea. Figure 25 was taken by Mr. T. Watanabe in Ebina, Japan on 12th Dec. 2012. Mr. T. Hayashi of Toyama Science Museum took a movie of flashing NIWAKA on 14th Dec. 2012. The optical signal was also detected by a photo-multiplier mounted on our telescope (Figure 22).

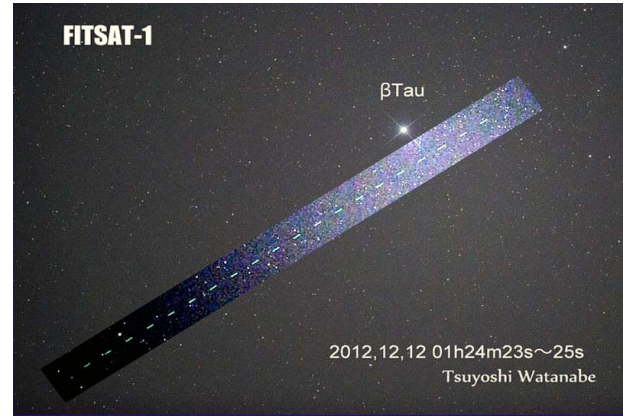

Fig. 25. Flashing Green LEDs with 10Hz mode

## XII. CONCLUSIONS

Both the main and the secondary missions completed successfully. Also, we discovered the phenomenon of an increase in the rotation of the satellite. We are now developing a model of this increasing rotation.

## ACKNOWLEDGMENT

We would like to thank the many people who helped to develop NIWAKA and enable its operation. JAXA advised us on developing NIWAKA and deploying it from ISS. We used The Nano-satellite Testing Center of Kyusyu Institute of Technology for space environment testing. Logical Product Corp. developed NIWAKA's 5.84 GHz system and main circuit board. Machining center staff at our institute made the NIWAKA body. Our students each developed their part of NIWAKA and took shifts to observe NIWAKA in flight.

Many ham radio operators worldwide sent signal and telemetry reports and participated in the 5.84 GHz transmission and flashing LEDs experiments. DF3GJ sent many reports of changing beacon signal strength. VK5HI sent many telemetry reports of interesting data. Especially, Dr. Simone Corbellini, who made a web page that helps to find NIWAKA in the constellations to observe NIWAKA flashing.

## REFERENCES

- [1] Takushi Tanaka and Takakazu Tanaka, "Development of a 5.8GHz-band High Speed Communication Radio Module for Small Artificial Satellites", Bulletin of Information Science Inst., Fukuoka Inst. Tech., vol.20, pp.1-6, 2009 (in Japanese).
- [2] Takushi Tanaka, Yoshiyuki Kawamura, and Takakazu Tanaka, "Structure and Functions of FITSAT-1 (NIWAKA)", 3rd UNISEC Space Takumi Conference, pp.1-11, 2012.